

Specialist in underground engineering equipment

Leading enterprise in comprehensive field of underground engineering

Supplier of complete underground engineering solutions



# SWDM160S

## MULTIFUNCTIONAL ROTARY DRILLING RIG

- ◆ Max. Drilling Diameter: 1500mm
- ◆ Operating Weight: 49t
- ◆ Engine Power: 186kW@2200rpm

### ▶ Performances and Features

#### ◆ Star Product

This model won the “TOP50 Products of China Construction Machinery 2021” market performance gold award.

#### ◆ Strong Power

Large power engine matches with large displacement motor. Main winch has fast speed. High torque of rotary head vibrates up and down to shake off soil, it's available to drill in soft and hard stratum.

#### ◆ High Stability

The luffing mechanism with dual boom and dual cylinder offers good stability and excellent pile quality; Laid with single layer in the condition of full drilling depth, the main winch steel rope has long service life.

#### ◆ Good Mobility

Even if transported with Kelly, the transport limit is still not exceeded, providing convenient change of worksites; With the hidden installation under the mast, outriggers help to place the pile casing on the hole mouth and make the chassis maintenance easier.

#### ◆ Safe Working

Special chassis with heavy-duty telescopic crawler and reinforced luffing mechanism which consists of dual boom provides reliable structure and excellent stability, empowering all-around construction ability; Good working safety is also ensured by multi-angle surveillance cameras and sound and light alarms.

#### ◆ Intelligent Control

Alarms are sent out by the failure self-diagnosis system; the operation parameters are displayed in real-time; The solenoid handle controls automatic drilling; the drill mast is erected and lowered by one-key pressing. Bottom protection is equipped for the Kelly, making the operation simple; Sunward Auspicious Cloud APP provides synchronous data transmission and real-time machine monitoring.



## ➤ Technical parameters

Working state (unit: mm)

ITEM		UNIT	SWDM160S
Drill hole	Max. Drilling Diameter	mm	1500
	Max. Drilling Depth	m	56/44
Rotary Head	Max. Torque	kN.m	168
	Rotating Speed	rpm	6~42
	high speed (optional)	rpm	70
Engine	Brand		Cummins
	Model		B6.7
	Power	kW/rpm	186/2200
	engine emission		Stage V
Main Winch	Lifting Force	kN	165
	Max. rope speed	m/min	80
	Rope Diameter	mm	28
Crowd system	Compression Force	kN	150
	Max.Lifting Force	kN	160
	Max. Stroke	mm	4000
Additional Wintch	Lifting Force	kN	50
	Lifting Speed	m/min	50
	Diameter of Rope	mm	16
Drilling Mast	Lateral inclination	°	±4
	Inclination Angle(front and back)	°	5/90
Chassis	Track Width	mm	700
	chassis extend&retract width	mm	2980~3980
	Chassis Length	mm	4645
Whole machine	working height	mm	18330
	Operating Weight	t	49
Kelly Bar	Friction Kelly Bar	m	D377-5X12.1(Standard)
	Interlocking Kelly Bar	m	D377-4X12.1

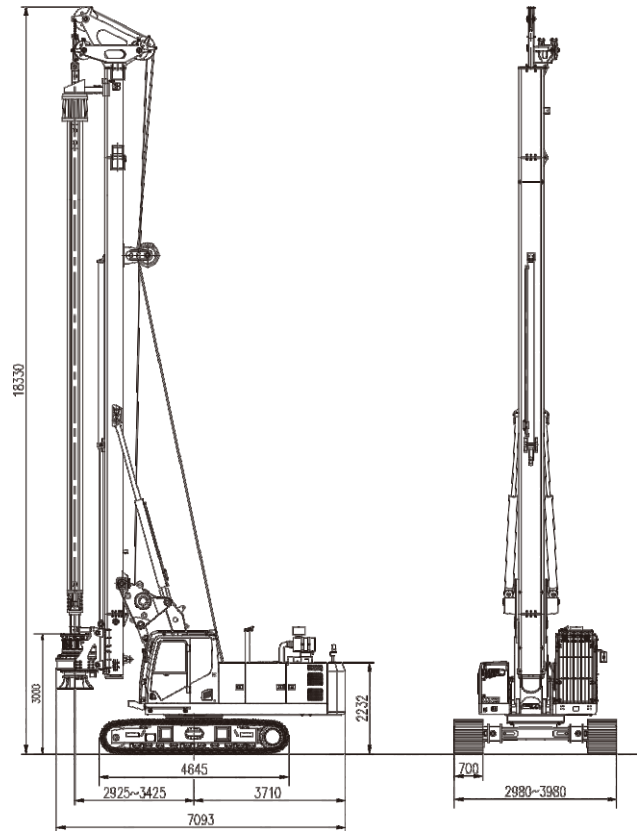

Transportation status (unit: mm)

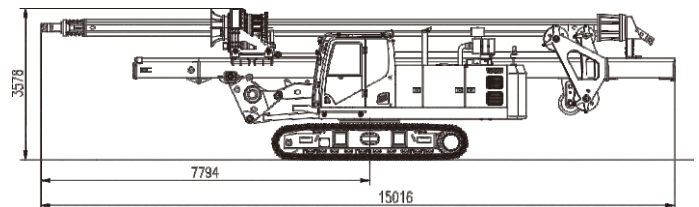

Be sure to read the operation and maintenance manual carefully before using the equipment. Adhering to the principle of continuous improvement, Sunward's products are subject to changes without prior notice. This sample is for reference only, and Sunward reserves the final right to interpret.

